

# Cell Membrane Electroporation with Arbitrary Pulse Waveforms

KAREL FLISAR, MARKO PUC,  
TADEJ KOTNIK, AND  
DAMIJAN MIKLAVCIC

*A System Design  
Based on Bipolar  
Amplification of Signals  
Generated by a  
Programmable  
Function Generator*

Exposure of a biological cell to an electric field can produce a variety of responses [1]-[6]. If the field strength exceeds a certain threshold value, this leads to a large transient increase in membrane conductivity and permeability for ions and molecules (electroporation, often also named electropermeabilization) or to fusion of adjacent cells (electrofusion) [5], [6]. Nowadays, these phenomena are widely used in applications such as gene transfection [7]-[8], preparation of monoclonal antibodies [9], and drug delivery, especially in electrochemotherapy of tumors [10]-[12]. For optimal effectiveness of these applications, one must choose the most appropriate amplitude, duration, and waveform of the applied electric pulses. With 2 mm distance between plate electrodes, which is an established setup for electroporation in vitro, the threshold voltages typically range from 120 to 300 V [13], with pulse durations from several microseconds to several milliseconds [5]. Due to these demands, electroporation is performed using specialized devices, often referred to as electroporators or electropulsators. Today, several such devices are commercially available [14], delivering either exponential or unipolar rectangular pulses with adjustable duration and amplitude. Often, the number of pulses and the intervals in which they are delivered can also be chosen.

However, it has been reported that efficiency of electroporation can be appreciably improved with other waveforms, such as bipolar rectangular pulses [15], or rectangular pulses with superimposed sine waves [16]. In addition, while unipolar pulses necessarily lead to electrolytic effects that are detrimental to the exposed cells [17], these effects can be reduced by use of symmetrical bipolar waveforms [18].

Commercially available generators of arbitrary waveforms cannot provide amplitudes in the range of several hundred volts that are necessary for electroporation. Furthermore, commercially available bipolar amplifiers that can be used to amplify the generated signals are i) limited in voltage to 400 V peak-to-peak, ii) limited in current to 2 A, iii) limited in frequency to several kHz, and, last but not least, iv) very costly. Thus, research of the role of pulse waveforms in the efficiency of electroporation has until now been limited to several laboratories with custom-built devices. It is only after an improved efficiency of a certain waveform has been well established that a commercial interest arises and these devices become available—usually, again at a considerable cost—to other laboratories.

In this article, we present a detailed design of a system for in vitro electroporation with arbitrary waveforms. A low-voltage signal is generated by a programmable function generator and amplified by a bipolar amplifier cir-

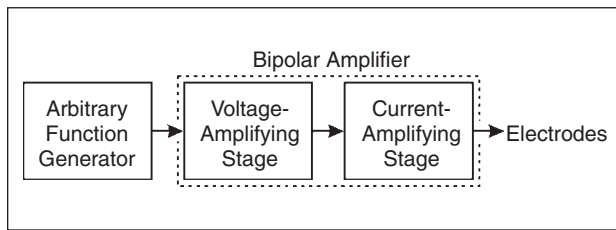

Fig. 1. Outline of the system.

circuit built from commercial components. We describe the general outline of the setup, give the scheme of the amplifier circuit, and present the frequency characteristics of the system. The total cost of the amplifier circuit components is less than US\$400, and with programmable function generators starting at approximately US\$1,000, this makes the presented design attainable to any laboratory with interest in electropermeabilization.

## System Design

Figure 1 shows the outline of the system design. A commercial arbitrary function generator (in our measurements, the Tektronix AFG 310) is used as a signal source, and the signal is amplified in two steps: first, the voltage-amplifying stage increases the signal voltage to a desired level (up to 520 V peak-to-peak in the presented design); then, the signal enters the current-amplifying stage, which ensures the power demanded by the load placed between the electrodes (up to 5.2 A in the presented design). The amplified signal is then delivered to the electrodes.

In the most affordable version, the arbitrary function generator in Figure 1 can be replaced by a basic nonprogrammable function generator, but in this case, the set of signals available is limited to the built-in waveforms.

## Bipolar Amplifier

The circuit of the bipolar amplifier is presented in Figure 2. The signal from the arbitrary function generator is delivered to the input (J2), the operational amplifier (OPA603) is used

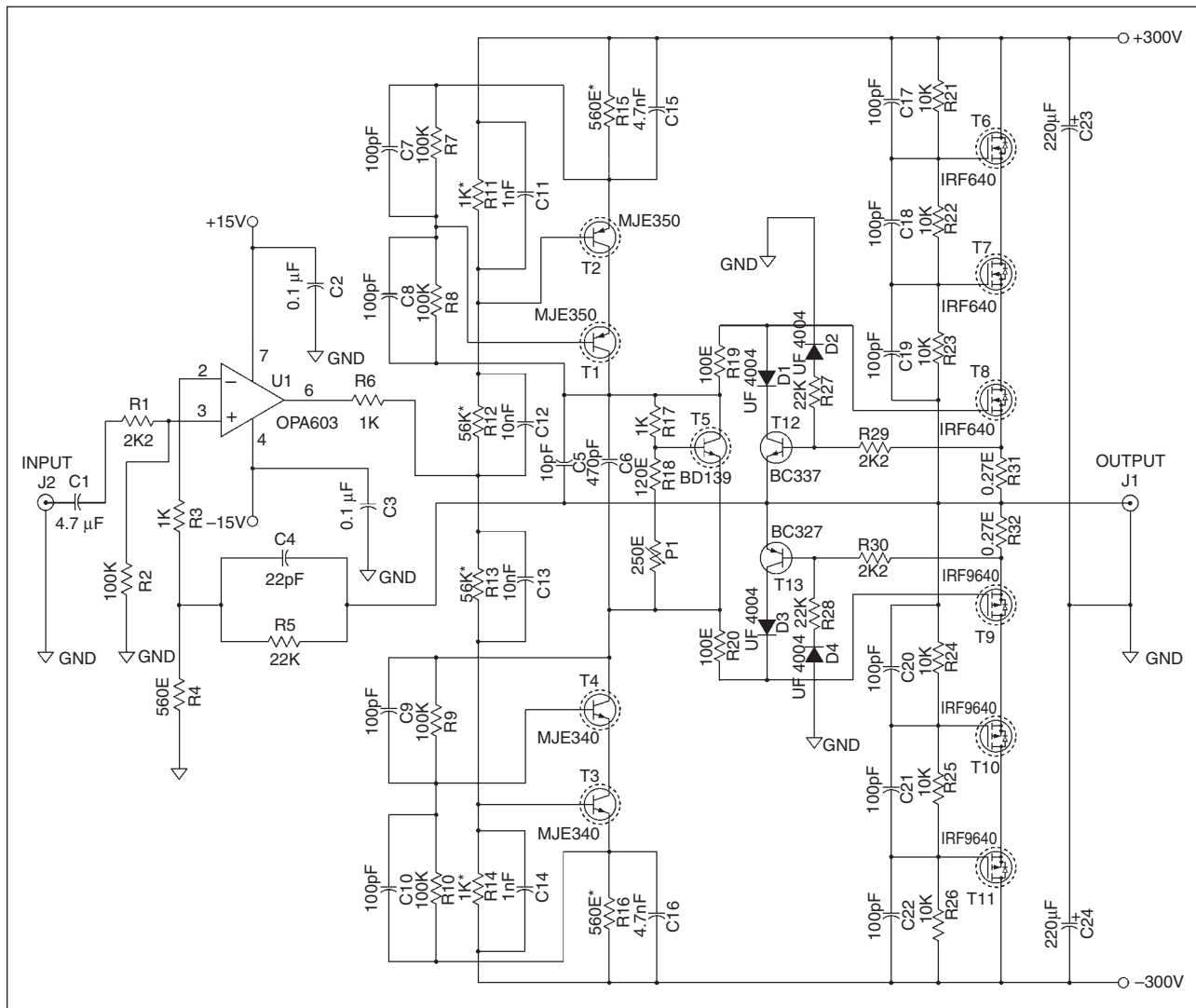

Fig. 2. The bipolar amplifier circuit. The dashed circles around the transistors T1-T11 represent a common heat sink that enhances the thermal stability of the circuit. The resistivities of R11-R16 (marked by an asterisk) should be fine-tuned to the values for which a zero output signal is obtained with a zero input signal.

for differential amplification, and the output signal of the operational amplifier enters the voltage-amplifying stage (transistors T1-T4). Transistor T5 serves for temperature stabilization and, together with the trimmer P1, for regulation of quiescent current. Transistors T6-T11 form the current-amplifying stage that provides the power demanded by the load at the output (J1). The capacitors in parallel to the resistors of the circuit compensate for the inductive behavior of the resistors with rapid fluctuations of the current. The system of diodes D1-D4 and transistors T12 and T13 serves as a protection against current overload. For optimal perfor-

mance, the transistors T1-T11 should be fixed to the same heat sink, all the transistors of the same type should come from the same production batch, and the resistivities of R11-R16 should be fine-tuned to provide a zero output signal with a zero input signal.

Within the bandwidth from 500 Hz up to 60 kHz and for the input amplitudes from 0.5 V up to 6.6 V (1.0 V-13.2 V peak-to-peak), the amplification of the bipolar amplifier circuit is 39.52 (31.94 dB), with maximum deviations of +0.60% and -0.61% reached at 500 Hz and 100 kHz, respectively (Figure 3, top). This amplification yields the maximum output amplitude of 260 V (520 V peak-to-peak), with the maximum allowable resistive load of 20 mS (50 Ω). At this load and a dc input signal of 6.6 V amplitude, dc current of 5.2 A is sustained for up to 1 ms; for longer durations, the output signal collapses. With a sine input signal having 6.6 V amplitude, stable ac current of 5.2 A amplitude is sustained for frequencies down to 500 Hz. Figure 3 also shows the frequency dependences of the phase shift between the input and the output voltage signal (middle) as well as the total shape distortion (TSD, bottom) evaluated as

$$\text{TSD} = \frac{\int_{t_1}^{t_2} |f_{\text{IN}}(t) - f_{\text{OUT}}(t - \tau)| dt}{\int_{t_1}^{t_2} |f_{\text{IN}}(t)| dt}$$

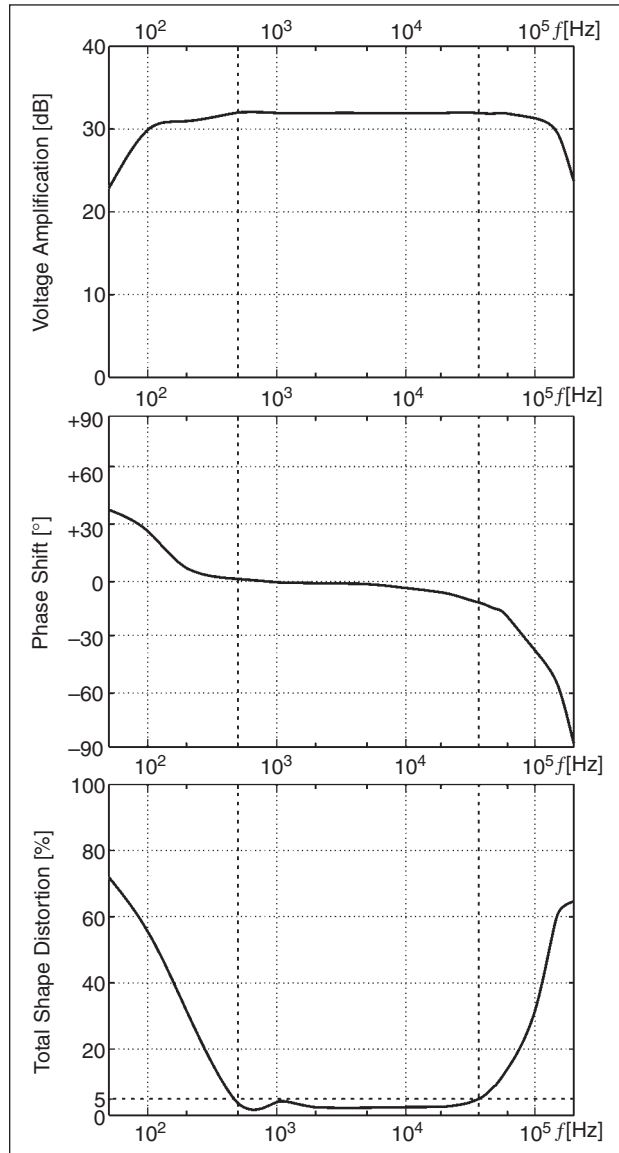

**Fig. 3.** Voltage amplification, phase shift, and total shape distortion of the bipolar amplifier circuit as functions of frequency. The dashed verticals bound the range from 500 Hz up to 35 kHz where total shape distortion is below 5%. The input amplitude was 6.25 V (12.5 V peak-to-peak), with a resistive load of 470 Ω at the output. Measurements were performed using a LeCroy LT9310C digital oscilloscope, a Tektronix P6101A 1:1 voltage probe (input signal), and a Tektronix P5100 1:100 voltage probe (output signal).

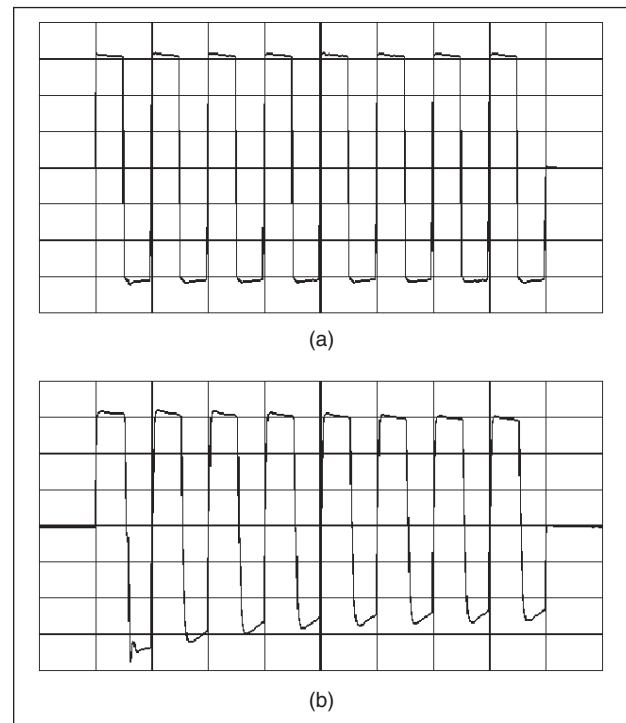
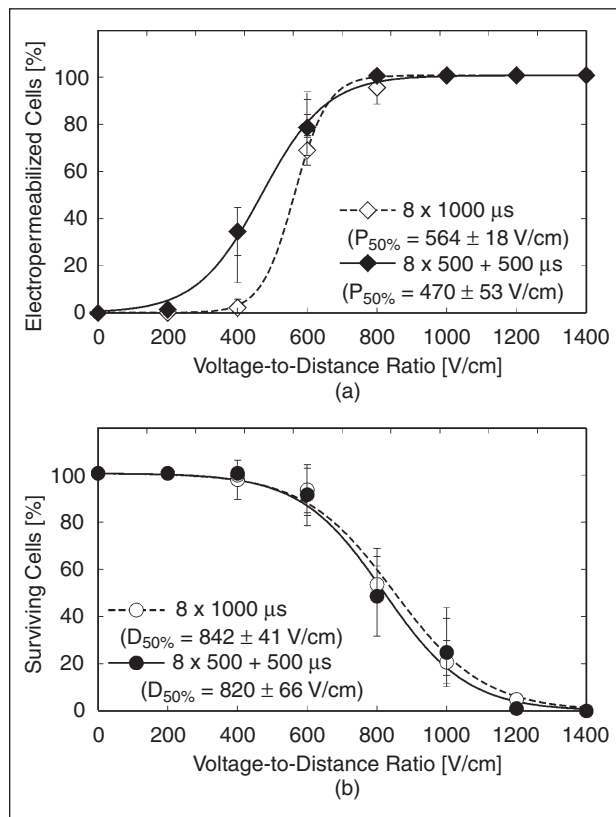

**Fig. 4.** The amplification of a burst of eight consecutive 100-μs symmetrical bipolar rectangular pulses. (a) The input signal (amplitude 6.25 V; i.e. 12.5 V peak-to-peak). (b) The output signal on the resistive load of 50 Ω (the minimum allowed resistance). Time division is 100 μs for both printouts, voltage division is 2 V for the top printout, and 75 V for the bottom printout. Measurements were performed using a LeCroy LT9310C digital oscilloscope, a Tektronix P6101A 1:1 voltage probe (input), and a Tektronix P5100 1:100 voltage probe (output).

where  $f_{IN}(t)$  is the input signal,  $f_{OUT}(t - \tau)$  is the output signal normalized to the amplitude and synchronized in phase with the input signal (the value of  $\tau$  is obtained from the phase shift), and the bounds of the interval  $t_1$  and  $t_2$  are chosen as to cover a representative sample of the two signals (in our case, five periods of the sine wave). As shown in Figure 3, total shape distortion is below 5% for the bandwidth from 500 Hz up to 35 kHz.

### Performance and Experimental Results

To illustrate the performance of the presented system, Figure 4 shows the amplification of a burst of rectangular pulses with the maximum output load (minimum resistance), while in Figure 5 we show the results of an experimental study in which the efficiency of the widely used protocol of electroporation of biological cells in suspension with a train of unipolar rectangular pulses was compared to a protocol using symmetrical bipolar rectangular pulses of the same amplitude and total duration.



**Fig. 5.** (a) Electroporation and (b) survival of DC3F cells (spontaneously transformed Chinese hamster fibroblasts) as functions of the pulse amplitude (the ratio between the voltage applied to the electrodes and the distance between them) with two protocols of electroporation: a train of eight 1-ms unipolar rectangular pulses delivered in intervals of 1 s, and a train of eight 1-ms symmetrical bipolar rectangular pulses delivered in intervals of 1 s.  $P_{50\%}$  and  $D_{50\%}$  are the pulse amplitudes that lead to permeabilization and death, respectively, of 50% of the cells. The details of the experimental protocol are described in [19].

### Conclusion

Unlike the commercially available devices used for electroporation, the system presented in this article provides a custom choice of the pulse waveform, with the amplitude from 0 up to 260 V (520 V peak-to-peak) with a shape distortion below 5% for the band from 500 Hz up to 35 kHz, and below 15% up to 55 kHz. The circuit can deliver currents up to 5.2 A, which, at the maximum output voltage, is obtained on a resistive load of 50 W. For larger loads (lower resistivity), the performance of the circuit is reduced, with a possibility of malfunction.

The presented system for in vitro cell membrane electroporation with arbitrary pulse waveforms consists of an arbitrary function generator, many of which are available on the market, and a bipolar amplifier circuit made entirely of commercial electronic components. With a total cost of the amplifier circuit components below US\$400, and with commercial programmable function generators starting at approximately US\$1,000, the presented design is within reach of any laboratory with interest in electroporation.

### Acknowledgment

This work was supported by the 5th Framework of the European Community and by the Ministry of Science and Technology of the Republic of Slovenia.

**Karel Flisar** was born in 1947 in Murska Sobota, Slovenia. He received his B.S.El.Eng. degree from the University of Ljubljana in 1980. He is currently working toward his M.S.El.Eng. degree at the Faculty of Electrical Engineering of the same university, where he is also the coordinator for industrial placement. His main research interest lies in the development of electronic circuits for biomedical engineering.

**Marko Puc** was born in 1975 in Ljubljana, Slovenia. He received his M.S.El.Eng. degree from the University of Ljubljana in 2001. He is currently preparing his Ph.D. thesis at the Faculty of Electrical Engineering of the same university. His main research interest lies in the study of the effects of electric fields on biological cells and development of electronic circuits for biomedical engineering.

**Tadej Kotnik** was born in 1972 in Ljubljana, Slovenia. He received the Ph.D. degree in biophysics from the University of Paris XI in 2000. He is currently a researcher at the Faculty of Electrical Engineering of the University of Ljubljana. His main research areas are membrane electrostatics and electrodynamics, as well as both theoretical and experimental study of the related biophysical phenomena.

**Damijan Miklavcic** was born in 1963 in Ljubljana, Slovenia. He received the Ph.D. degree in electrical engineering from the University of Ljubljana in 1993. He is currently a professor at the Faculty of Electrical Engineering of the same university. His main research areas are electroporation-assisted drug delivery, including cancer treatment by means of electrochemotherapy, tissue oxygenation, and modeling.

**Address for Correspondence:** Professor Damijan Miklavcic, Faculty of Electrical Engineering, University of Ljubljana,

## References

- [1] K.R. Robinson, "The responses of cells to electrical fields," *J. Cell Biol.*, vol. 101, pp. 2023-2027, 1985.
- [2] T. Kotnik and D. Miklavcic, "The second order model of transmembrane voltage induced by applied electric fields," *IEEE Trans. Biomed. Eng.*, vol. 47, pp. 1047-1081, 2000.
- [3] T. Kotnik and D. Miklavcic, "Theoretical evaluation of the distributed electric power dissipation in biological cells exposed to electric fields," *Bioelectromagnetics*, vol. 21, pp. 385-394, 2000.
- [4] T. Kotnik and D. Miklavcic, "Analytical description of transmembrane voltage induced by electric fields on spheroidal cells," *Biophys. J.*, vol. 79, pp. 670-679, 2000.
- [5] T.Y. Tsong, "Electroporation of cell membranes," *Biophys. J.*, vol. 60, pp. 297-306, 1991.
- [6] I.G. Abidor and A.E. Sowers, "Kinetics and mechanism of cell membrane electrofusion," *Biophys. J.*, vol. 61, pp. 1557-1569, 1992.
- [7] M.P. Rols, C. Delteil, M. Golzio, P. Dumond, S. Cros, and J. Teissié, "In vivo electrically mediated protein and gene transfer in murine melanoma," *Nat. Biotechnol.*, vol. 16, pp. 168-171, 1998.
- [8] E. Neumann, S. Kakorin, and K. Toensing, "Fundamentals of electroporative delivery of drugs and genes," *Bioelectrochem. Bioenerg.*, vol. 48, pp. 3-16, 1999.
- [9] J. Lukas, J. Bartek, and M. Strauss, "Efficient transfer of antibodies into mammalian cells by electroporation," *J. Immunol. Methods*, vol. 170, pp. 255-259, 1994.
- [10] G. Serša, M. Cemažar, and D. Miklavcic, "Antitumor effectiveness of electrochemotherapy with cis-diamminedichloroplatinum(II) in mice," *Cancer Res.*, vol. 55, pp. 3450-3455, 1995.
- [11] L.M. Mir, L.F. Glass, G. Serša, J. Teissié, C. Domenge, D. Miklavcic, M.J. Jaroszeski, S. Orlowski, D.S. Reintgen, Z. Rudolf, M. Belehradek, R. Gilbert, M.P. Rols, J. Belehradek Jr., J.M. Bachaud, R. DeConti, B. Štabuc, M. Cemažar, P. Coninx, and R. Heller, "Effective treatment of cutaneous and subcutaneous malignant tumors by electrochemotherapy," *Br. J. Cancer*, vol. 77, pp. 2336-2342, 1998.
- [12] L.M. Mir and S. Orlowski, "Mechanisms of electrochemotherapy," *Adv. Drug. Deliv. Rev.*, vol. 35, pp. 107-118, 1999.
- [13] M. Cemažar, T. Jarm, D. Miklavcic, A. Macek-Lebar, A. Ihan, N.A. Kopitar, and G. Serša, "Effect of electric-field intensity on electroporation and electrosensitivity of various tumor-cell lines *in vitro*," *Electro. Magnetobiol.*, vol. 17, pp. 261-270, 1998.
- [14] G.A. Hofmann, "Instruments and electrodes for *in vivo* electroporation," in *Electrochemotherapy, Electrogenotherapy, and Transdermal Drug Delivery*, M.J. Jaroszeski, R. Heller, and R. Gilbert, Eds. Totowa, NY: Humana Press, 2000, pp. 37-62.
- [15] O. Tovar and L. Tung, "Electroporation of cardiac cell membranes with monophasic or biphasic rectangular pulses," *Pacing Clin. Electrophysiol.*, vol. 14, pp. 1887-1892, 1991.
- [16] D.C. Chang, "Cell poration and cell fusion using an oscillating electric field," *Biophys. J.*, vol. 56, pp. 641-652, 1989.
- [17] J.W. Loomis-Husselbee, P.J. Cullen, R.F. Irvine, and A.P. Dawson, "Electroporation can cause artefacts due to solubilization of cations from the electrode plates," *Biochem. J.*, vol. 277, pp. 883-885, 1991.
- [18] T. Kotnik, D. Miklavcic, and L.M. Mir, "Cell membrane electroporation by symmetrical bipolar rectangular pulses. Part II. Reduced electrolytic contamination," *Bioelectrochemistry*, vol. 54, pp. 91-95, 2001.
- [19] T. Kotnik, A. Macek-Lebar, D. Miklavcic, and L.M. Mir, "Evaluation of cell membrane electroporation by means of a nonpermeant cytotoxic agent," *Biotechniques*, vol. 28, pp. 921-926, 2000.